

ALFA

"TRUNNION MOUNTED" BALL VALVES

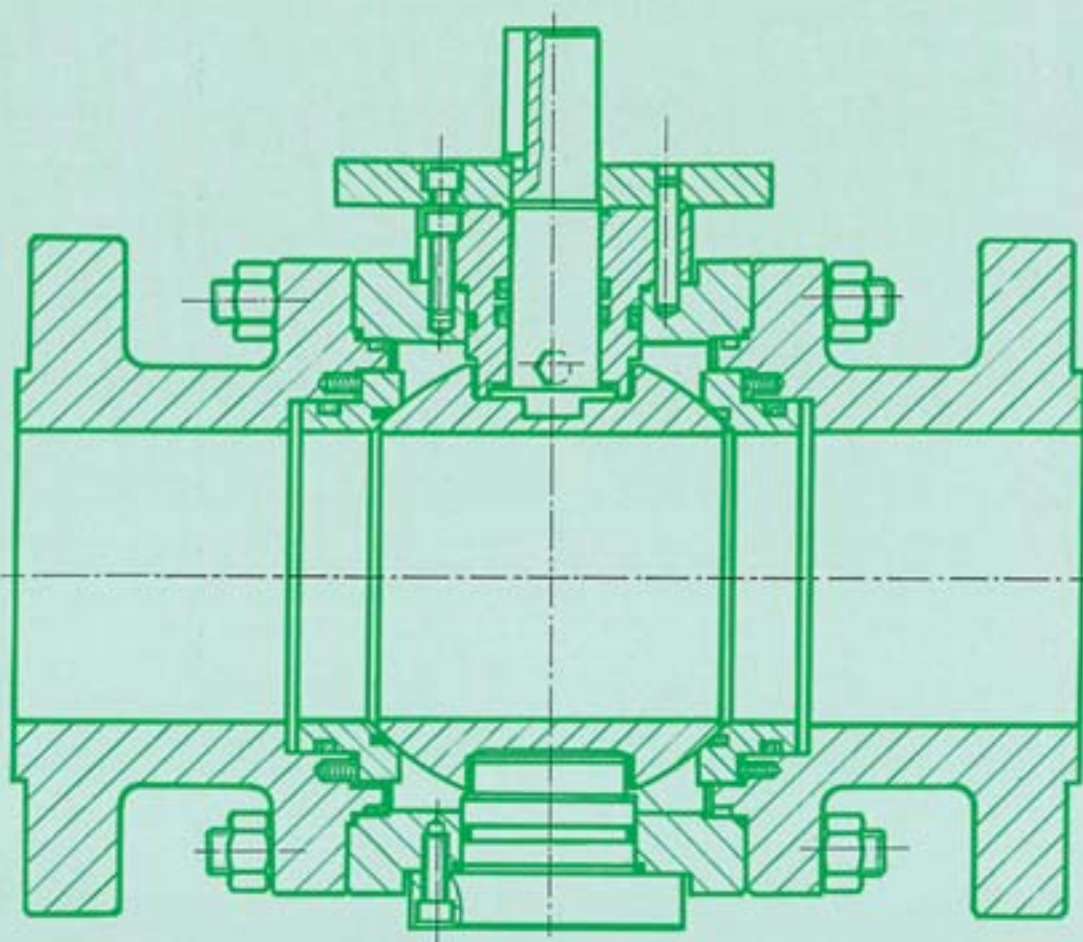

All rights reserved. No part of this publication may be reproduced or transmitted, in any form or by any means, electronic, mechanical, photocopying, recording or otherwise, without the prior permission of ALFA VALVOLE s.r.l.

Design and specifications are subject to change without notice, except those established by international standards. Ed. 000101.06



ALFA
VALVOLE s.r.l.

© 20010 CASOREZZO (Milano) - Italia -
VIALE DEL LAVORO, 19
Tel. 02.90296206 r.a. - Telefax 02.90296292
E-Mail: alfavalvole@alfavalvole.it - Sito internet: www.alfavalvole.it

"TRUNNION MOUNTED" BALL VALVES

ALFA

ALFA VALVOLE "TRUNNION MOUNTED" SIDE ENTRY BALL VALVES

GENERAL DESCRIPTION

ALFA VALVOLE "TRUNNION MOUNTED" Ball Valves are designed to satisfy all the requirements of API 6D for pipeline service by utilizing the proper materials to meet the requirements of the service conditions for different fluids and pressures up to ANSI class 2500/PN 420. **ALFA VALVOLE** "TRUNNION MOUNTED" Ball Valves are designed to withstand hydrocarbon corrosion as well as the severe service conditions that occur during start-up, ensuring a long life. The technical solutions drawn up for the petro-chemical industry can be successfully used in other industrial fields.

Easy maintenance can be carried out in the dynamic seal areas.

CONSTRUCTION

BODY

The body of the **ALFA VALVOLE** "TRUNNION MOUNTED" Ball Valve is manufactured from forged pieces in compliance with ASTM standards. This type of design gives a good homogeneous material structure ensuring a long working life for the valve.

STEM

The stem is constructed separately from the ball. The stem is designed with an integral pin which permits perfect positioning with the ball. The stem is of an anti blow out design. The load pressure on the ball (thrust) is absorbed by special bearings fitted on the ball trunnions (upper and lower), thus ensuring no side thrust on the stem, which permits a very low operating torque and a long life.

STEM SEAL

The stem seal is obtained by a set of three gaskets (triple barrier) ensuring perfect tightness. Furthermore, if required, the upper gasket can be easily replaced by disassembling the upper part only.

On request a lubricator is available in order to inject lubricant and/or sealing grease, if necessary.

BODY/CLOSURE SEAL

A set of two gaskets ensures tightness even in the case of an environmentally harmful medium.

SEAT SEAL

ALFA VALVOLE "TRUNNION MOUNTED" Ball Valves are designed to guarantee a perfect tightness between ball and seat, by means of a primary soft seal of suitable material and of a secondary metal seal.

Tightness is obtained by providing the necessary seat thrust on the ball.

Ed. 000101.06/P0001

Design and specifications are subject to change without notice, except those established by international standards.



**ALFA
VALVOLE s.r.l.**

© 20010 CASOREZZO (Milano) -Italia-
VIALE DEL LAVORO, 19
Tel. 02.90296206 r.a. - Telefax 02.90296292
E-Mail: alfavalvole@alfavalvole.it - Sito internet: www.alfavalvole.it

"TRUNNION MOUNTED" BALL VALVE

ALFA

ALFA VALVOLE "TRUNNION MOUNTED" Ball Valve seats are manufactured in two basic types:

1) **SELF RELIEVING SEAT** (fig. 1 and fig. 2)

fig. 1) Shows that inlet pressure works on seat area "A" which is wider than area "B"; therefore the differential area creates a piston effect which forces the seat against the ball surface producing a tight effective seal.

fig. 2) Shows the self relieving feature when the pressure in the body cavity exceeds the inlet or the outlet pressure. In this case area "C" is wider than area "D" and when the piston effect created becomes greater than the constant spring load, the self relieving effect is obtained.

2) **DOUBLE PISTON EFFECT SEAT** (fig. 3 and fig. 4)

fig. 3) Shows that inlet pressure works on seat area "A" which is wider than area "B"; therefore the differential area creates a piston effect which forces the seat against the ball surface, producing a tight effective sealing.

fig. 4) Shows the pressure inside the body on seat area "D" which is wider than area "C"; therefore the differential area creates a piston effect which forces the seat against the ball, producing a tight effective seal.

LOW OPERATING TORQUE

The ball operates on a fixed axis established by bearing blocks located on the upper and lower ball trunnions. The ball trunnions revolve in an oilless bearing which does not require lubrication. The main feature of this bearing is a reduced friction factor with a better load resistance.

This feature combines to assure lower operating torque.

DOUBLE BLOCK AND BLEED

This is the capability of a valve, in a pipeline under pressure, to have its body cavity bled down to atmospheric pressure when the valve is in fully closed position.

ALFA VALVOLE "TRUNNION MOUNTED" Ball Valves are designed for services requiring "double block and bleed". The upstream and downstream seat bubble-tight design permits venting and draining of line fluids from the body cavity. Small body cavities permit rapid drainage.

Bubble-tight sealing is achieved without lubricants, which completely eliminates product contamination. Double block and bleed design with emergency grease seal is available on request.

All rights reserved. No part of this publication may be reproduced or transmitted, in any form or by any means, electronic, mechanical, photocopying, recording or otherwise, without the prior permission of ALFA VALVOLE s.r.l.

Ed. 000101.06/P0001

Design and specifications are subject to change without notice, except those established by international standards.



ALFA
VALVOLE s.r.l.

20010 CASOREZZO (Milano) -Italia-
VIALE DEL LAVORO, 19
Tel. 02.90296206 r.a. - Telefax 02.90296292
E-Mail: alfavalvole@alfavalvole.it - Sito internet: www.alfavalvole.it

"TRUNNION MOUNTED" BALL VALVE

ALFA

SELF RELIEVING SEATS

STANDARD EXECUTION

FIG. 1



$A > B$

FLOW LINE



FIG. 2

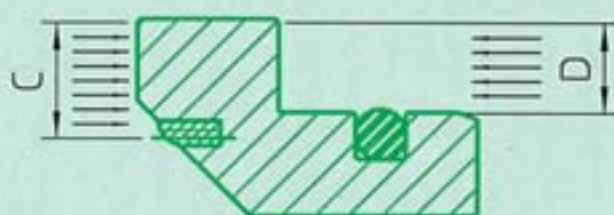

$C > D$

FLOW LINE



DOUBLE PISTON EFFECT

FIG. 3



$A > B$

FLOW LINE



FIG. 4



$C < D$

FLOW LINE



Ed. 0001/01.05/P0001

Design and specifications are subject to change without notice, except those established by international standards.

ALFA VALVOLE “TRUNNION MOUNTED” SIDE ENTRY BALL VALVES

MAIN CHARACTERISTICS

- 1 - Face to face and bore dimensions according to API 6D standard, latest edition; different dimensions on request.
- 2 - Flanged and butt welding ends according to ANSI B16.5 and ANSI B16.25; other types of connections on request.
- 3 - Nickel-plated ball and seat (for Carbon Steel material); other materials on request.
- 4 - Valve body in forged steel. Body and side end are designed to withstand bending loads.
- 5 - The stem is constructed separately from the ball and is of anti blow out design.
- 6 - Triple-barrier stem sealing. Upper stem seal ring can be replaced on line under pressure.
- 7 - Self relieving.
- 8 - Double block and bleed feature.
- 9 - The adapter plate is constructed to easily match stem extension, gearing and power operators.
- 10 - Full bore and reduced bore construction available.
- 11 - Bubble-tight seat sealing construction.
- 12 - Low operating torque.

ON REQUEST

- 13 - Teflon impregnated metal sleeve.
- 14 - Metal to metal sealing with precision metal seat rings.
- 15 - Double-piston effect feature.
- 16 - Body relief valve.
- 17 - Secondary sealing device. Valves can be supplied with a sealant injection system for emergency shut-off and for high pressure services.
- 18 - Fire-safe according to EN ISO 10497 - API 607 V ed.
- 19 - Antistatic device according to BS 5146.
- 20 - Extended stem.
- 21 - Material and special execution according to Customer Specs (carbon steel, inox steel, special alloys).

